

SEA JAY

ALUMINIUM BOATS



5.4 BARRA MASTA

SEA JAY
Platinum Series

Edition 12

DELUXE MODELS

Introducing Who We Are

Sea Jay Aluminium Boats is a family company founded by Col and Janelle Glass in 1989. Boating has always played a major part in their family life spanning many years. Both Col and Janelle have been proactive in many aspects of boating including recreational fishing, tournament fishing (for the mighty Barra), water skiing and boat racing. Manufacturing aluminium boats became a natural progression into the boating industry although they never dreamed their "Sea Jay Aluminium Boats" brand would one day become a household name throughout Australia.

Joining his parents with their passion Troy Glass became an employee of the company in 1999. Completing his apprenticeship within the industry, Troy soon put his theoretical and practical knowledge to good use and became the manager of research and development. In 2010, Troy became a part owner of Sea Jay Boats further strengthening the family values associated within the company.

Constantly growing since its inception, the Sea Jay Boats factory now covers 7,000m² and with 2,280m² under roof, provides the necessary room to build Sea Jay's pressed and plate range of aluminium boats.

Commitment

Sea Jay bring their product to you with personal pride and trust you will enjoy many memorable moments on some of the best waterways this country has to offer. Only the highest quality marine grade aluminium and components are used to construct one of the most robust range of boats with a quality of finish enviable of other brands on the market today.

What a better way to relax by GETTING AMONGST IT in a quality Sea Jay Aluminium Boat you can rely on and trust.



When Buying A Boat

Purchasing a new boat should be a time of excitement and anticipation. Every one is unique and has a range of wants and needs influencing the type of vessel most suited to them. If you have been involved in boating for numerous years you will be familiar with its many aspects and have a good idea on the specifications you are after. However, if this is your first time purchasing a boat we would like to offer some basic advice to think about.

The very first thing to consider is what marine environment you are planning to use your new boat in. Will you be fishing lakes and impoundments? Maybe creeks and estuaries? Or perhaps offshore? The type of activities you plan to partake in also play an equally important role in the design and layout of the model you will choose. For instance, flicking lures will require a different layout than if you're objective is bottom bashing.

Engine requirements also play an important part in your boat choice. Most boat manufacturers will usually list a recommended minimum and maximum horsepower rating as well as engine weight on each model of boat. While you can not legally exceed the maximum horsepower rating, under powering a boat can also be detrimental to overall performance and safety. Some factors to take into account are as follows:-

- Weight of the boat
- Amount of fuel onboard
- How many people onboard
- Weight of accessories
- Distance to and from destination

Hull performance can be spoilt by an incorrectly fitted or trimmed engine. If you are new to boating and have had little experience with outboard engines, your dealer (or manufacturer) will guide you with the correct engine transom position and explain about motor trimming. In this instance going for a water test is also strongly advisable.

While the model and engine horsepower must be considered if you intend to carry a big load, how the load is distributed is equally important. Too much weight in one area may compromise the boats performance and safety on the water.

Choosing a new trailer is just as significant as choosing a suitable boat and engine. The specifications of a trailer can vary considerably but should be able to accommodate the weight of the boat, engine, a full tank of fuel and any other equipment that would normally be brought along. Incorrect trailer set up is one of the major causes of boat damage, so

it is important when deciding on a trailer to consider several factors:-

- The distance you will be traveling
- The type of road surface you will be towing on
- Where the boat will be launched
- Vehicle towing capacity
- Hull type (e.g. Pressed or Plate bottoms)
- Hull weight

Remember, whoever your looking at buying from, whether it be from a dealer or a private sale, don't be afraid to ask questions. If they don't know the answers or aren't very helpful, then you may have to question if they are the right people to deal with. It is crucial that you are happy with who and what you're spending your hard earned money on. This is your dream purchase after all.

We hope the information we have provided helps you along in your decision process when purchasing a new boat or boat package. Boating is a terrific past time that can be enjoyed by all ages and purchasing a new boat should definitely be part of it.

Hope to see you on the water soon.....

Happy Boating!



CONTENTS

SPECIALITY OPEN BOAT

Allrounder	6
Territory	7
Escape	8
Escape Sports	9
Castaway	10

V-NOSE

Swift	11
Discovery	12
Discovery Sports	13

TOURNAMENT

Viper	14
Quick Strike	15

CONSOLE

Haven	16-17
Haven Sports	18
Barra Masta	19
Tropic	20

RUNABOUT

Ranger	21
Seeker	22
Classic	23
Capri	24

BOWRIDER

Wanderer	25
----------	----

CABIN

Venture Cab	26
-------------	----

COLOURS & DIMENSIONS

27

OPTIONS & ACCESSORIES

28-29

WARRANTY

30

Sea Jay Advantage

With over 70 models to choose from ranging in size from 2.45m to 6.1m Sea Jay has models to cover all boating enthusiasts. Our boats are made to the highest level of workmanship and come with Quality fittings and various options. Due to the quality of build you can also rest assured that with Sea Jay you are buying a boat that not only looks good but also has great Stability and Performance. High side and wide beams are available ensuring strength, protection and the all important space you require. Whether you are newbie to the water ways, a seasoned pro, expert fisherman or recreational boatie, Sea Jay will have a model for you. Models also available for the commercial sector.



Quality & Workmanship

- Quality and pride in workmanship is an important aspect of the manufacturing process.
- Sea Jay ensures employees build their product with the pride of workmanship they would expect in a boat of their own. This motto is carried through the entire manufacturing process.
- Sea Jay employees receive on the job training by qualified personal.
- A quality checking system is in place to check material and product at each stage throughout the manufacturing process. All attempts are made to provide a quality product to enter the market place.



Research & Development

Our Research & Development department is responsible for innovations in products, design, construction and style. Completely managed at our factory, our R & D team are relentless in the pursuit of creating innovative new products to keep Sea Jay Aluminium Boats one step ahead of the competition. Some of the key elements focused on are as follows.

- New model research and advancement
- Source and incorporate new and innovative products
- Continual revision and enhancement of current models
- Refine and modernise production processes
- Acquire and learn new Technologies to improve hull design and function

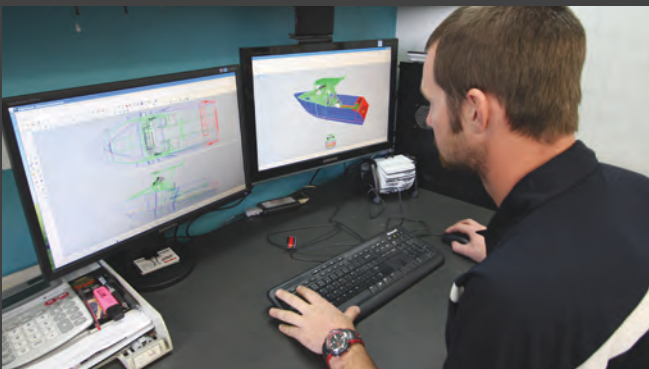
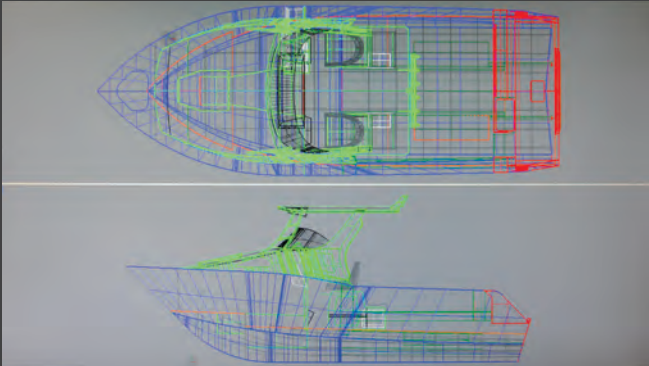



Sure Trac Hulls

What does the term "Sure Trac Hull" mean? Put simply, it means any Sea Jay hull that has a reverse chine incorporated into it. Of course it isn't just a simple matter of just slapping on a reverse chine and hoping for the best. Each Sure Trac hull has been designed by taking into account the hull density (material thickness), transom deadrise, degree of bow entry, weight distribution and the maximum engine horse power to be used. The reverse chine is then shaped around each of these determining factors using our latest 3D modelling program.

What is the end result?

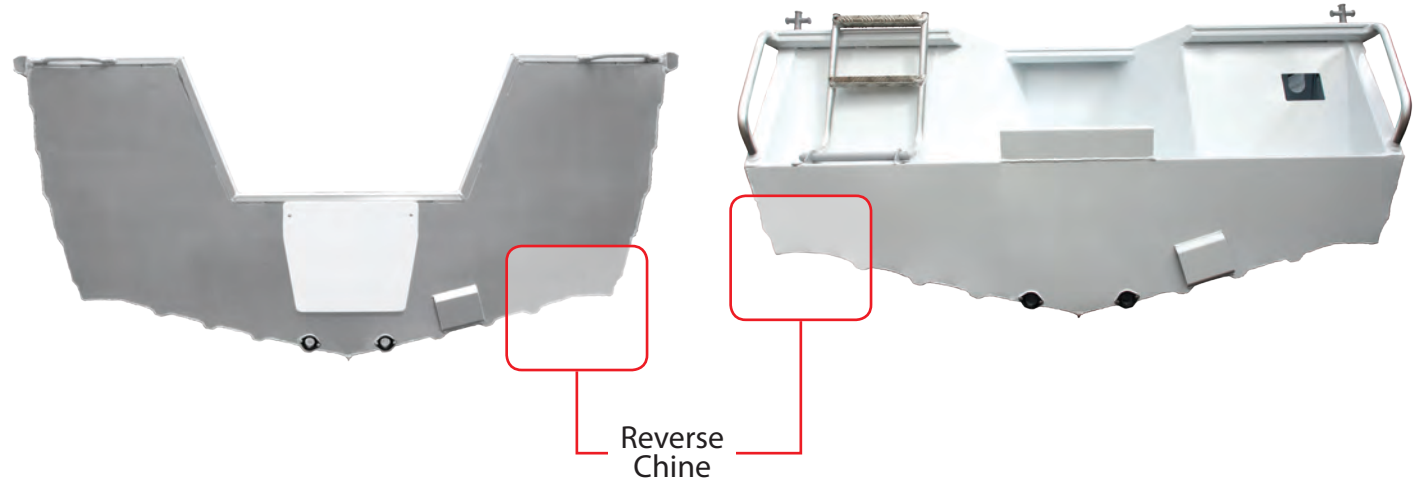
Our Sure Trac Hull enhances the performance of any boat as the reverse chine creates stability at rest while the deeper V provides a smooth, controlled ride that's second to none. The reverse chine also achieves maximum hole shot capability (fast on the plane) and with the lift given, optimal fuel efficiency is achieved with only minimum engine power required.





Sure Trac Hull

- Enhanced stability at rest
- Deeper V creating a smoother ride
- Quicker on plane with minimal power
- Optimal fuel efficiency achieved
- Superior performance in handling & tracking



Ultimate Edge Transom

- Designed for Maximum Hull Strength
- Handles any (2) and (4) stroke engines
- Large boarding platform for easy entry
- Maximises internal cockpit space
- Utilizes space for storage

SPECIALTY OPEN BOATS **ALLROUNDER**

Trying to find a Boat to suit many different estuary applications can be tough; however our ALLROUNDER models have made this choice easy. A full open floor creates a copious amount of room that carries fishing rods & tackle, crab pots, nets and camping gear with room to spare. An Anchorwell and long side pocket allows for even more storage with a Sounder Mount Plate also fitted for extra convenience. Topped off with wide side decks for strength (and a place to fit rod holders), many Seat Pedestal positions and a rear step & rail for ease of entry, the ALLROUNDER is more than capable to suit your fishing needs.



For the latest & additional information on this model please visit www.seajayboats.com.au/models/open-boat/allrounder or scan the QR Code with your Smart Phone



SPECIFICATIONS

	4.2	4.4	4.55
bottoms (mm)	2.0	2.0	3.0
sides (mm)	1.6	1.6	3.0
beam (m)	1.95	1.97	2.05
depth (m)	0.99	0.99	1.08
floor ribs	9	10	11
no. of persons	4	4	5
weight approx (kg)	216	226	278
rec hp	30	30	40
max hp	40	40	50
max motor weight (kg)	98	110	120

FEATURES

anchor well	•	•	•
bollard -front	•	•	•
bungs – 38mm x 2	•	•	•
floatation – under floor	•	•	•
floor – carpeted / plywood	•	•	•
gunwhale rubber inserts	•	•	•
handle – rear (starboard side)	•	•	•
navigation light plates	•	•	•
rear step & rail – large (port side)	•	•	•
rope shelf	•	•	•
side pocket – long (starboard side)	•	•	•
sounder mount plate	•	•	•
spray chines	•	•	•
sure trac hull – reverse chine	-	-	•
switch panel plate	•	•	•
towing eye – double	•	•	•
transducer bracket	•	•	•
wide side decks	•	•	•

TRANSOM

standard (l/s)	•	•	•
----------------	---	---	---

RAILS

bow - short	•	•	•
-------------	---	---	---

SEATS

standard plastic swivel	2	2	2
seat sockets	5	5	5

SPECIFICATIONS

	4.2	4.4	4.55	4.85
bottoms (mm)	2.0	2.0	3.0	3.0
sides (mm)	1.6	1.6	3.0	3.0
beam (m)	1.95	1.97	2.05	2.14
depth (m)	0.99	0.99	1.08	1.09
floor ribs	9	10	11	13
no. of persons	4	4	5	5
weight approx (kg)	228	239	290	317
rec hp	30	30	40	50
max hp	40	40	50	60
max motor weight (kg)	105	110	120	120

FEATURES

anchor cavity	•	•	•	•
battery & tank rack – under cast deck	•	•	•	•
bungs – 38mm x 2	•	•	•	•
cast platform – front to bow / hatches x 2	•	•	•	•
floor – carpeted plywood	•	•	•	•
floatation – under floor	•	•	•	•
fuel line – under floor – tank rack to transom	•	•	•	•
gunwhale rubber inserts	•	•	•	•
handles – rear	•	•	•	•
minnkota plate – on bow	•	•	•	•
side pockets – long	•	•	•	•
sounder mount	•	•	•	•
spray chines	•	•	•	•
sure trac hull – reverse chine	•	•	•	•
switch panel plate	•	•	•	•
towing eye – double	•	•	•	•
transducer bracket	•	•	•	•
wide side decks	•	•	•	•

TRANSOM

standard (l/s)	•	•	•	•
----------------	---	---	---	---

RAILS

bow – low profile / nav light plates	•	•	•	•
rear	•	•	•	•

SEATS

standard plastic swivel	2	2	2	2
seat sockets	7	6	6	6

SPECIALTY OPEN BOATS **TERRITORY**

If quietly flicking lures in and around snags or going crabbing is more your kind of fun, then the TERRITORY is for you. The TERRITORY features a full front cast platform with two hatches and a tank rack to neatly stow away your fuel tank. A minn kota plate and battery rack are also standard, ready for when you want to take your fishing to the next level.



For the latest & additional information on this model please visit www.seajayboats.com.au/models/open-boat/territory or scan the QR Code with your Smart Phone



SPECIALTY OPEN BOATS **ESCAPE**

Want to escape the pressure of work? How about the hustle and bustle of everyday living? Escaping what life throws at you has never been easier than in our ESCAPE range of Boats. An oversized front Casting Platform is standard which conveniently houses an Anchor Cavity, Battery Rack and Dry Storage Box. With a rear Casting Platform that hides a 1/2 Tank Rack underneath for extra storage as well as a Live Bait Tank, all Escape models are equipped with everything needed and more to make your day on the water hassle free. What are you waiting for..... ESCAPE NOW!



For the latest & additional information on this model please visit www.seajayboats.com.au/models/open-boat/escape or scan the QR Code with your Smart Phone



SPECIFICATIONS

	4.2	4.4	4.55
bottoms (mm)	2.0	2.0	3.0
sides (mm)	1.6	1.6	3.0
beam (m)	1.95	1.97	2.05
depth (m)	0.99	0.99	1.08
floor ribs	9	10	11
no. of persons	4	4	5
weight approx (kg)	252	282	325
rec hp	30	40	40
max hp	40	40	50
max motor weight (kg)	105	110	120

FEATURES

anchor cavity	•	•	•
battery rack – under cast deck	•	•	•
bungs – 38mm x 2	•	•	•
cast platform – front / carpeted / hatch	•	•	•
cast platform – rear / carpeted / hatch	•	•	•
dry storage box	•	•	•
floor – carpeted plywood	•	•	•
floatation – under floor	•	•	•
gunwhale rubber inserts	•	•	•
handles – rear	•	•	•
live bait tank – plumbed	•	•	•
minnkota plate – on bow	•	•	•
paint – chine up & inside (coloured sides opt)	•	•	•
pinstripping	•	•	•
rod holders x 4	•	•	•
side pockets	•	•	•
sounder mount	•	•	•
splash well – small	•	•	•
spray chines	•	•	•
sure trac hull – reverse chine	-	-	•
switch panel plate	•	•	•
tank rack (1/2) – under rear cast deck	•	•	•
towing eye – double	•	•	•
transducer bracket	•	•	•
wide side decks	•	•	•

TRANSOM

standard (l/s)	•	•	•
----------------	---	---	---

FUEL TANK

under floor – floor fill	-	60	60
--------------------------	---	----	----

RAILS

bow – short / nav light plates	•	•	•
rear	•	•	•

SEATS

full upholstered folding seats & pedestals	2	2	2
seat sockets	4	5	5

SPECIFICATIONS

4.4 4.55

bottoms (mm)	2.0	3.0
sides (mm)	1.6	3.0
beam (m)	1.97	2.05
depth (m)	0.99	1.08
floor ribs	10	11
no. of persons	4	5
weight approx (kg)	304	347
rec hp	40	50
max hp	50	60
max motor weight (kg)	120	120

FEATURES

anchor cavity	.	.
battery rack – under cast deck	.	.
bungs – 38mm x 2	.	.
cast platform – front / carpeted / hatch	.	.
cast platform – rear / carpeted / hatches	.	.
console (side) – screen / shelf	.	.
drink holders x 2	.	.
dry storage box	.	.
floor – carpeted plywood	.	.
flotation – under floor	.	.
gunwhale rubber inserts	.	.
handles – rear	.	.
live bait tank – plumbed	.	.
electric motor plate	.	.
paint – chine up & inside (coloured sides opt)	.	.
pin striping	.	.
rod holders x 4	.	.
side pockets	.	.
sounder mount	.	.
splash well – small	.	.
spray chines	.	.
steering – hydraulic	opt	opt
steering – push pull	.	.
sure trac hull – reverse chine	.	.
tank rack (1/2) – under rear cast platform	.	.
towing eye – double	.	.
transducer bracket	.	.
wide side decks	.	.

TRANSOM

standard (l/s)	.	.
----------------	---	---

FUEL TANK

under floor / deck fill / gauge	60	60
---------------------------------	----	----

RAILS

bow – short / nav light plates	.	.
rear	.	.

SEATS

full upholstered folding seats & pedestals	2	2
seat sockets	5	5

ESCAPE SPORTS SPECIALTY OPEN BOATS

When looking at the already feature packed ESCAPE range of Boats, one could be forgiven in thinking that nothing else could be done to improve on it. Not resting on our laurels, we added a Side Console, thus creating the ESCAPE SPORTS. Having a Side Console creates many benefits such as room to house your Sounder, Gps and Radio, protection from the elements whilst traveling and easier control of the Boat (as novice boaties find tiller steer more difficult to master). Perhaps the greatest benefit is the power rating on all the SPORTS models has been increased by 10hp, truly making them the SPORTS models of the ESCAPE range.



For the latest & additional information on this model please visit www.seajayboats.com.au/models/console/escape-sports or scan the QR Code with your Smart Phone



SPECIALTY OPEN BOATS **CASTAWAY**

If an estuary boat with the characteristics of being a “Jack of all trades” is what you’re searching for, then our CASTAWAY range of aluminium boats might just be the ticket. The CASTAWAY features a full carpeted floor with seat sockets galore to position your pedestal seating in just the right spot. The front casting platform is equipped with a twin hatch to allow easy access and the tank rack below holds up to a 45ltr plastic fuel tank. An alloy flow through bait tank keeps your bait alive without the need of a fully plumbed system but what is truly unique with this model is the “Set Down Foredeck”. This deck allows you to sort your catch while draining directly outside the boat, not into your hull.



For the latest & additional information on this model please visit www.seajayboats.com.au/models/open-boat/castaway or scan the QR Code with your Smart Phone



SPECIFICATIONS

	4.2	4.4	4.55
bottoms (mm)	2.0	2.0	3.0
sides (mm)	1.6	1.6	3.0
beam (m)	1.95	1.97	2.05
depth (m)	0.99	0.99	1.08
floor ribs	9	10	11
no. of persons	4	4	5
weight approx (kg)	225	240	291
rec hp	30	30	40
max hp	40	40	50
max motor weight (kg)	98	110	120

FEATURES

bungs – 38mm x 2	•	•	•
cast platform – front / hatches x 2	•	•	•
floor – carpeted plywood	•	•	•
floatation – under floor	•	•	•
gunwhale rubber inserts	•	•	•
handles – rear	•	•	•
live bait tank – non plumbed	•	•	•
paint – chine up & inside (coloured sides opt)	•	•	•
pinstriping	•	•	•
rod shelf	•	•	•
set down foredeck	•	•	•
side pocket – starboard side	•	•	•
sounder mount	•	•	•
spray chines	•	•	•
sure trac hull – reverse chine	-	-	•
switch panel plate	•	•	•
towing eye – double	•	•	•
Transducer Bracket	•	•	•
wide side decks	•	•	•

TRANSOM

standard (l/s)	•	•	•
----------------	---	---	---

RAILS

bow – short / nav light plates	•	•	•
rear	•	•	•

SEATS

full upholstered folding seats & pedestals	2	2	2
seat sockets	8	7	7

SPECIFICATIONS

3.85

4.1

4.4

bottoms (mm)	1.6	1.6	2.0
sides (mm)	1.6	1.6	1.6
beam (m)	1.69	1.79	1.90
depth (m)	0.73	0.88	0.99
floor ribs	8	9	10
no. of persons	4	4	4
weight approx (kg)	190	210	241
rec hp	20	25	30
max hp	25	30	40
max motor weight (kg)	73	80	110

FEATURES

anchor cavity	•	•	•
bungs – 38mm x 2	•	•	•
cast platform – front to bow / hatches x 2	•	•	•
Fuel line under floor	•	•	•
full floor – carpeted plywood	•	•	•
flotation under floor	•	•	•
gunwhale rubber inserts	•	•	•
Handles – rear	•	•	•
Side Pocket – starboard side only	•	•	•
Sounder mount plate	•	•	•
spray chines	•	•	•
switch panel plate	•	•	•
tank rack – under front casting platform	•	•	•
towing eye – double	•	•	•
transducer bracket	•	•	•
wide side decks	•	•	•

TRANSOM

standard (s/s)	•	•	-
standard (l/s)	•	•	•

RAILS

bow – short / nav light plates	•	•	•
rear	•	•	•

SEATS

welded rear thwart	opt	opt	opt
standard plastic swivel	2	2	2
seat sockets	5	5	5

SWIFT V-NOSE

Our SWIFT range of V Nose Punts are for the angler who wants more useable features than just a pair of thwart seats and a rope shelf that most traditional dinghies have to offer. A full carpeted floor with (5) floor sockets allows for greater seat positioning and combined with a raised casting platform, gives 360° of fishable area. To keep the floor clutter free, a tank rack is located under the casting platform with a CE certified fuel line running under the floor to the transom. Wide side decks are also a standard feature that provide maximum strength and functionality.



For the latest & additional information on this model please visit www.seajayboats.com.au/models/v-nose-punt/swift or scan the QR Code with your Smart Phone



V-NOSE DISCOVERY

The DISCOVERY range of aluminium boats have been designed for the fishing enthusiast who desires more than just a tinnie. Standard with paint inside and out, this model is not only protected from the marine environment, but looks impressive as well. A rear casting platform provides a high vantage point to sight and flick lures at those elusive fish with a tank rack underneath for additional storage. With a plumbed live bait tank ready to keep your bait fish alive and well, the DISCOVERY range of aluminium boats will provide you with every chance of a successful day fishing.



For the latest & additional information on this model please visit www.seajayboats.com.au/models/v-nose-punt/discovery or scan the QR Code with your Smart Phone



SPECIFICATIONS

	4.1	4.4
bottoms (mm)	1.6	2.0
sides (mm)	1.6	1.6
beam (m)	1.79	1.90
depth (m)	0.88	0.99
floor ribs	9	10
no. of persons	4	4
weight approx (kg)	225	255
rec hp	25	30
max hp	30	40
max motor weight (kg)	85	110

FEATURES

anchor cavity	•	•
battery rack – under front hatch	•	•
bungs – 38mm x 2	•	•
cast platform – front to bow / hatches x 2	•	•
cast platform – rear / carpeted	•	•
electric motor mount – on bow	•	•
floor – carpeted plywood	•	•
fuel line – front storage rack to transom	•	•
flotation under floor	•	•
gunwhale rubber inserts	•	•
handles – rear	•	•
live bait tank – plastic plumbed	•	•
paint – chine up and inside (coloured sides Opt)	•	•
pinstriping	•	•
rod holders x 2	•	•
spray chines	•	•
storage rack – under front cast platform	•	•
switch panel plate	•	•
tank rack (1/2) – under rear bulkhead	•	•
towing eye – double	•	•
transducer bracket	•	•
wide side decks	•	•

TRANSOM

standard (l/s)	•	•
----------------	---	---

RAILS

bow – short / nav light plates	•	•
rear	•	•

SEATS

full upholstered folding seats & pedestals	2	2
seat sockets	4	4

DISCOVERY SPORTS V-NOSE

SPECIFICATIONS

	4.4	4.65
bottoms (mm)	2.0	3.0
depth – incl. console rail	1.29	1.27
sides (mm)	1.6	3.0
beam (m)	1.90	2.08
depth (m)	0.99	0.99
floor ribs	10	11
no. of persons	4	4
weight approx (kg)	275	372
rec hp	40	60
max hp	50	80
max motor weight (kg)	120	180
overall length (m)	4.4	4.65

FEATURES

anchor cavity	•	•
battery rack – under front hatch	•	•
bungs – 38mm x 2	•	•
cast platform – front / carpeted / hatch	-	•
cast platform – front / carpeted / hatches x 2	•	-
cast platform – rear / hatch	•	-
cast platform – rear / hatched x 2	-	•
console (side) – screen / shelf	•	•
electric motor mount – on bow	•	•
floor – carpeted plywood	•	•
flotation under floor	•	•
fuel line – from front storage rack to transom	•	•
gunwhale rubber inserts	•	•
handles – rear	•	•
live bait tank – plumbed	•	•
paint – chine up and inside (coloured sides Opt)	•	•
pinstriping	•	•
rod holders	•	•
spray chines	•	•
steering – hydraulic	opt	opt
steering – push pull	•	•
tank rack – under front cast platform	•	-
tank rack (1/2) – under rear cast platform	•	-
tank rack – under rear cast platform	-	•
towing eye – double	•	•
transducer bracket	•	•
wide side decks	•	•

TRANSOM

standard (l/s)	•	-
ultimate edge (l/s)	-	•

FUEL TANK

under floor / deck fill / gauge	-	65
---------------------------------	---	----

RAILS

bow – short / nav light plates	•	•
console screen	•	•
rear transom	-	•

SEATS

full upholstered folding seats & pedestals	2	2
seat sockets	4	4

For an even greater fishing experience, the DISCOVERY SPORTS is equipped with a side console designed with the sports fisherman in mind. Low enough to avoid casting lines, the console is still large enough to accommodate modern electronics and to hide behind if the weather picks up. Fully upholstered folding seats add just a touch of comfort with seat positions aplenty. With an engine power rating of 10hp more than the Discovery, the DISCOVERY SPORTS will take you to your favourite spot with time to spare.



For the latest & additional information on this model please visit <http://www.seajayboats.com.au/models/v-nose-punt/discovery-sports> or scan the QR Code with your Smart Phone



TOURNAMENT VIPER

Here is one for the tournament angler, the new Sea Jay 4.65 Nomad Viper. The 4.65 VIPER is designed exclusively for the tournament angler or the passionate fisherman; with its sleek lines and attention to detail, the VIPER is an impressive addition to the Sea Jay Range.

A large deck height casting area with handy storage hatches, live well, bait tank, under floor fuel, stylish console and screen and a full transom with boarding platform are just a few of the standard features offered in this model.



For the latest & additional information on this model please visit www.seajayboats.com.au/models/tournament/viper or scan the QR Code with your Smart Phone

SPECIFICATIONS

4.65

bottoms (mm)	3.0
sides (mm)	3.0
beam (m)	2.08
depth (m)	0.99
depth – incl. console rail	1.27
floor ribs	11
no. of persons	4
weight approx (kg)	418
rec hp	80
max hp	90
max motor weight (kg)	195
overall length (m)	4.65

FEATURES

accessory pre rig	•
anchorwell – carpeted lid	•
battery storage – under front hatch	•
bungs – 38mm x 2	•
cast platform – front / carpeted / hatch	•
cast platform – rear / carpeted / hatch x2	•
console – sports (with screen)	•
electric motor mount	•
floor – carpeted plywood	•
floatation – under floor	•
gunwale rubber inserts	•
live bait tank – plumbed	•
paint – chine up & inside (coloured sides opt)	•
pinstriping	•
rod holders x 5	•
spray chines	•
steering – hydraulic	opt
steering – push pull	•
storage – under bench seats	•
storage – under step	•
live well – front / plumbed	•
towing eye – double	•
transducer bracket	•
wide side decks	•

TRANSOM

ultimate edge	•
---------------	---

FUEL TANK

under floor / deck fill / gauge	65
---------------------------------	----

RAILS

bow – short / nav light plates	•
transom	•

SEATS

folding bench with back rest	•
------------------------------	---



SPECIFICATIONS

5.0

bottoms (mm)	4.0
sides (mm)	3.0
beam (m)	2.12
depth (m)	0.90
floor ribs	13
no. of persons	3
weight approx (kg)	490
rec hp	90
max hp	115
max motor weight (kg)	230
overall length (m)	5.0

FEATURES

- accessory pre rig
- anchorwell – carpeted lid
- battery storage – under front hatch
- bungs – 38mm x 2
- cast platform – front / carpeted / hatch
- cast platform – rear / carpeted / hatch
- console - sports (with screen)
- electric motor mount
- floor – carpeted plywood
- floatation – under floor
- gunwhale rubber inserts
- live bait tank – rear / plumbed / 30ltr
- paint – chine up & inside (coloured sides opt)
- pinstripping
- spray chines
- steering – hydraulic
- storage under bench seats
- towing eye – double
- transducer bracket
- wide side decks – to bow

TRANSOM

- intra pod

FUEL TANK

- under floor / deck fill / gauge 100

RAILS

- bow – short / nav light plates
- transom

SEATS

- folding bench with back rest

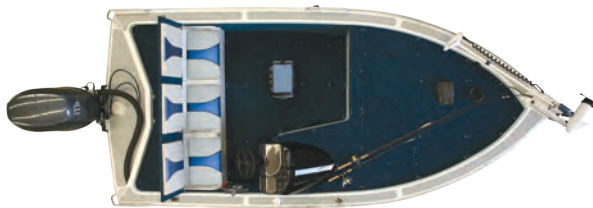

QUICKSTRIKE TOURNAMENT

Striking a blow in the Sports Fishing Market is the new high performance, incredibly fishable QuickStrike. On inspection of the Sea Jay QuickStrike, serious anglers will identify the superior qualities of its design, durable construction & first class finish. Excellent handling, rough water comfort & top end performance is delivered to you by its Sure Trac Hull. Rated to 115hp, it has an exceptional hole shot, planning easily & efficiently.

The QuickStrike reveals Sea Jay's "Intra Pod" – Integrated Pod Construction. Not only is the integrity of the pod superior & more aesthetically pleasing, but it also incorporates a larger boarding area which may be utilized as additional fishing space.

Also appearing is the unique fold up bench seating for three, perfectly placing the driver in alignment of its sporty fiberglass dash, further enhancing the sports fishing appeal of this sleek hull. Huge decks & superior performance makes it a sports fishing standout: from first light to weigh-in, the QuickStrike will have you ahead of the competition.



For the latest & additional information on this model please visit www.seajayboats.com.au/models/tournament/quickstrike or scan the QR Code with your Smart Phone

CONSOLE HAVEN

Our HAVEN range embraces one of the most functional fishing designs, the timeless centre console layout. The console is positioned centrally in all models to allow for 360° of uninterrupted fishing space with an alloy storage box and an upholstered lid for seating. Every HAVEN model features our Sure Trac Hull to provide stability, sure footed handling and optimum fuel economy. The Ultimate Edge Transom is also a standard feature that provides a large boarding platform for ease of entry as well as providing transom strength to handle the power and weight of modern (2) and (4) stroke engines. A proven workhorse, the HAVEN will adapt to almost any fishing conditions.



SPECIFICATIONS

	4.55	4.85	5.0	5.4	5.8	6.1
bottoms (mm)	3.0	3.0	3.0	4.0	4.0	4.0
sides (mm)	3.0	3.0	3.0	3.0	3.0	3.0
beam (m)	2.10	2.15	2.24	2.44	2.44	2.49
depth (m)	1.10	1.15	1.21	1.30	1.35	1.40
depth – incl. console rail (m)	1.70	1.75	1.86	2.01	2.10	2.15
floor ribs	12	13	13	15	16	17
no. of persons	5	5	5	6	6	7
weight approx (kg)	340	350	425	553	557	669
rec hp	50	60	75	100	130	130
max hp	60	80	100	135	150	150
max motor weight (kg)	120	180	195	230	230	230
overall length (m)	4.7	4.95	5.2	5.67	5.92	6.22

FEATURES

	4.55	4.85	5.0	5.4	5.8	6.1
accessory pre rig	opt	opt	opt	opt	opt	opt
anchorwell – large with 3mm flat foredeck	•	•	•	•	•	•
bait board	opt	opt	opt	opt	opt	opt
bait tank	opt	opt	opt	opt	opt	opt
battery & oil rack – in stern	•	•	•	•	•	•
bollards x 3	•	•	•	•	•	•
bow sprit & roller	•	•	•	•	•	•
bungs – 38mm x 2	•	•	•	•	•	•
console (side) – screen / shelf	•	•	•	•	•	•
console (side) – screen / shelf / folding top	•	•	•	•	•	•
dive door	•	•	•	•	•	•
drink holders x 2	•	•	•	•	•	•
floor – carpeted plywood	•	•	•	•	•	•
flotation – under floor	•	•	•	•	•	•
front step up floor – hatch	•	•	•	•	•	•
gunwhale rubber inserts	•	•	•	•	•	•
ladder	opt	opt	opt	opt	opt	opt
paint – chine up & inside (coloured sides opt)	•	•	•	•	•	•
pinstriping	•	•	•	•	•	•
rod holders x 2	•	•	•	•	•	•
rounded foredeck	•	•	•	•	•	•
side pockets	•	•	•	•	•	•
ski hooks x 2	•	•	•	•	•	•
spray chines	•	•	•	•	•	•
steering – hydraulic	opt	opt	opt	•	•	•
steering – push pull	•	•	•	•	•	•
sure trac hull – reverse chine	•	•	•	•	•	•
towing eye – double	•	•	•	•	•	•
transducer bracket	•	•	•	•	•	•
wide side decks	•	•	•	•	•	•

TRANSOM

ultimate edge (l/s)	•	•	•	•	•	•
ultimate edge (ul/s)	•	•	opt	•	•	•

FUEL TANK

under floor / deck fill / gauge	65	85	105	140	160	220
---------------------------------	----	----	-----	-----	-----	-----

RAILS

bow – low profile	•	•	•	•	•	•
console screen	•	•	•	•	•	•
rear & transom	•	•	•	•	•	•

SEATS

folding rear lounge	opt	opt	opt	•	•	•
folding rear lounge (¾)	•	•	•	opt	opt	opt
welded storage bin – upholstered lid	•	•	•	•	•	•
back rest for storage bin	opt	opt	opt	opt	opt	opt



For the latest & additional information on this model please visit www.seajayboats.com.au/models/console/haven or scan the QR Code with your Smart Phone



CONSOLE HAVEN SPORTS

Designed along similar lines as the Haven, the HAVEN SPORTS has been tweaked with the sports fishing enthusiast in mind. A low side console has been fitted to provide maximum cockpit space yet will still house modern gauges and electronics with ease. A raised front casting platform gives a higher vantage point to sight your prey with an added bonus of underfloor storage to allow for an uncluttered deck. Seating comes in the form of fully upholstered folding pedestal seats with no less than (4) seating positions in all models. With a large anchorwell and bow sprit providing easy anchor retrieval and storage, the HAVEN SPORTS has all the elements needed to get you in the strike zone.



For the latest & additional information on this model please visit www.seajayboats.com.au/models/console/haven-sports or scan the QR Code with your Smart Phone



SPECIFICATIONS

	4.55	4.85	5.0	5.4
bottoms (mm)	3.0	3.0	3.0	4.0
sides (mm)	3.0	3.0	3.0	3.0
beam (m)	2.10	2.15	2.24	2.44
depth (m)	1.10	1.15	1.21	1.30
depth – incl. console rail (m)	1.30	1.35	1.41	1.56
floor ribs	12	13	13	15
no. of persons	5	5	5	6
weight approx (kg)	365	385	470	550
rec hp	50	60	75	100
max hp	60	80	100	135
max motor weight (kg)	120	180	195	230
overall length (m)	4.7	4.95	5.2	5.67

FEATURES

	opt	opt	opt	opt
accessory pre rig	•	•	•	•
anchorwell – with 3mm flat foredeck	•	•	•	•
bait board	•	•	•	opt
bait tank	opt	opt	opt	opt
battery & oil rack – in stern	•	•	•	•
bollards x 3	•	•	•	•
bow sprit & roller	•	•	•	•
bungs – 38mm x 2	•	•	•	•
cast platform – hatch	•	•	•	•
console (side) – screen / shelf	•	•	•	•
dive door	•	•	•	•
drink holders x 2	•	•	•	•
floor – carpeted plywood	•	•	•	•
flotation – under floor	•	•	•	•
gunwhale rubber inserts	•	•	•	•
ladder	opt	opt	opt	opt
paint – chine up & inside (coloured sides opt)	•	•	•	•
pinstriping	•	•	•	•
rod holders x 4	•	•	•	•
round foredeck	•	•	•	•
side pockets	•	•	•	•
ski hooks x 2	•	•	•	•
spray chines	•	•	•	•
steering – hydraulic	opt	opt	opt	•
steering – push pull	•	•	•	•
sure trac hull – reverse chine	•	•	•	•
towing eye – double	•	•	•	•
transducer bracket	•	•	•	•
wide side decks to bow	•	•	•	•

TRANSOM

ultimate edge (l/s)	•	•	•	•
ultimate edge (ul/s)	•	•	opt	•

FUEL TANK

under floor / deck fill / gauge	65	85	105	140
---------------------------------	----	----	-----	-----

RAILS

bow – low profile / nav light plates	•	•	•	•
console screen	•	•	•	•
rear & transom	•	•	•	•

SEATS

folding rear lounge	opt	opt	opt	•
folding rear lounge (¾)	•	•	•	opt
full upholstered folding seats & pedestal	2	2	2	2
seat sockets	4	4	4	4

SPECIFICATIONS

	4.55	4.85	5.0	5.4
bottom (mm)	3.0	3.0	3.0	4.0
sides (mm)	3.0	3.0	3.0	3.0
beam (m)	2.1	2.15	2.24	2.44
depth (m)	1.1	1.15	1.21	1.3
depth (m) inc screen	tba	1.5	1.53	1.84
floor ribs	12	13	13	15
no. of persons	5	5	5	6
weight approx. (kg)	tba	465	503	635
rec / max HP	50/60	60/80	75/100	100/135
max motor weight (kg)	120	180	195	230
overall length (m)	4.7	4.95	5.2	5.67

FEATURES

	opt	opt	opt	opt
accessory pre rig	opt	opt	opt	opt
anchorwell
bait tank – alloy	opt	opt	opt	.
bait board – removable with 4 x rod holders
battery & oil rack in stern
battery rack under cast deck
bollard x 3
bow sprit & roller
bungs 38mm x 2
console – side (includes screen/shelf)
console – centre towards rear (incl screen/shelf)
console shelf – forward of console
dive door
drink holder x 2
electric motor plate – extended off gunwhale
ice box storage under front cast deck
front casting platform with 2 x hatches
flotation – under floor
floor – carpet / plywood
gunwhale rubber insert
painted – chine up & inside
pin stripping
platinum sides (3mm plate)
rod holders (plastic) x 4
rod storage holder (vertical) – holds 5 x rods
side pockets
spray chines
steering – hydraulic	opt	opt	opt	.
steering – push pull
sure trac hull – reverse chine
battery rack – under casting deck
towing eye (double)
transducer bracket
wide side decks

TRANSOM

ultimate edge (l/s)
ultimate edge (u/s)

FUEL TANK

under floor / deck fill / gauge	65	85	105	140
---------------------------------	----	----	-----	-----

RAILS

low bow rails – with nav light plates
console screen grab rail
rear rails
rear transom rails

SEATS

full upholstered folding seats & pedestal	2	2	2	2
seat sockets	4	4	4	6

BARRA MASTA CONSOLE

The BARRA MASTA has definitely kept true to its name as it has every option you would need to fish the Top end, or anywhere for that matter. Raised casting platforms, removable bait boards, electric motor plates and rod holders galore are just some of the extensive features this model has to offer. Purpose built for the new wave of fishing enthusiasts, the BARRA MASTA has been designed for maximum deck space with minimal clutter. This has been achieved by eliminating the largest space hogging necessity in every boat (the esky) by raising and lengthening the front casting platform creating a cavity underneath large enough to hide not just the esky, but life jackets, tackle boxes, casting nets or anything else you may need for a great day out on the water.



For the latest & additional information on this model please visit www.seajayboats.com.au/models/console/barramasta or scan the QR Code with your Smart Phone



CONSOLE TROPIC

For a true workhorse in all styles of fishing you can't go past the TROPIC. This model comes in either a centre or side console positioned towards the rear to allow for maximum deck space. A huge front casting platform conceals a large dry storage box to keep valuables from becoming wet but can also double as a kill tank. A motorwell fully seals the transom area to eliminate water coming on board and an underfloor fuel tank is standard to keep you on the water all day. This model will handle anything thrown at it from trolling a lure to line fishing at your favorite spot yet is still capable of sneaking up a creek to drop a crab pot or two.



For the latest & additional information on this model please visit www.seajayboats.com.au/models/console/tropic or scan the QR Code with your Smart Phone



SPECIFICATIONS

	4.4	4.55	4.85	5.35
bottoms (mm)	2.0	3.0	3.0	3.0
sides (mm)	1.6	3.0	3.0	3.0
beam (m)	1.97	2.05	2.14	2.20
depth (m)	0.99	1.08	1.09	1.10
depth – incl. console rail (m)	tba	1.44	1.45	1.60
floor ribs	10	11	13	14
no. of persons	4	5	5	6
weight approx (kg)	272	353	377	434
rec hp	40	60	60	80
max hp	50	60	70	80
max motor weight (kg)	120	120	120	180

FEATURES

anchor cavity	•	•	•	•
battery & tank rack – under cast deck	•	•	•	•
bungs – 38mm x 2	•	•	•	•
cast platform – front to bow / hatches x 2	•	•	•	•
console (centre or side) – screen / shelf	•	•	•	•
dry storage in cask deck	-	•	•	•
floor – carpeted plywood	•	•	•	•
flotation – under floor	•	•	•	•
fuel line (under floor) – tank rack to transom	•	-	-	-
gunwhale rubber inserts	•	•	•	•
handles – rear	•	•	•	•
live bait tank – alloy floor mount	•	-	-	-
electric motor plate – on bow	•	•	•	•
pinstriping	-	•	•	•
rod holders x 6	•	•	•	•
side pockets	•	•	•	•
spray chines	•	•	•	•
steering – hydraulic	opt	opt	opt	opt
steering – push pull	•	•	•	•
sure trac hull – reverse chine	-	•	•	•
tank rack – under cast deck	•	•	•	•
towing eye – double	•	•	•	•
transducer bracket	•	•	•	•
wide side decks to bow	•	•	•	•

TRANSOM

motor well	-	•	•	•
standard long shaft	•	•	•	•

FUEL TANK

under floor / deck fill / gauge	-	60	60	75
---------------------------------	---	----	----	----

RAILS

bow – nav light plates	•	•	•	•
console screen	•	•	•	•

SEATS

Full upholstered folding seats & pedestals	2	2	2	2
seat sockets	6	6	6	6

SPECIFICATIONS

4.4

4.7

bottoms (mm)	3.0	4.0
sides (mm)	3.0	3.0
beam (m)	2.0	2.14
depth (m)	1.04	1.09
floor ribs	10	11
no. of persons	4	5
weight approx (kg)	323	400
max hp – tiller steer	40	60
max hp – with side console	50	70
max motor weight (kg)	105	120

FEATURES

Anchor Cavity	•	•
Bollard – front	•	•
Bow Sprit	•	•
Bungs – Alloy x 2	•	•
Capped Keel	opt	•
Checkerplate Floor – fully welded	•	•
Casting Platform (front) to Bow with 2 x Hatches	•	•
Casting Platform (rear) with 2 x Hatches	-	•
Console Box	•	•
Console – side	opt	opt
Electric Motor Plate – extended off gunwhale	•	•
Gunwhale Rubber Insert	•	•
Handles Rear	•	•
Inspection Port – Plastic	-	•
Inspection Port – Alloy with spanner	•	•
Keel – External	•	-
Keel – Internal	-	•
Long Side Pocket – starboard side only	•	•
Reverse Chine	•	•
Splash Well	•	•
Spray Chines	•	•
Towing Eye (Double)	•	•
Transducer Bracket	•	•
Under Floor Flotation	•	•
Wide Side Decks to Bow	•	•

TRANSOM

Standard Long Shaft	•	•
---------------------	---	---

RAILS

Bow Rails – with Nav Light Plates	•	•
Rear Rails	•	•

SEATS

Full Upholstered Folding Swivel	2	2
Seat Sockets	5	5

PRO SERIES RANGER

Designed to handle all the “TUFF STUFF” the Ranger is well suited for the pro fisherman and die-hard anglers. Available as a 4.4m with 3mm bottom and reverse chine or the beefed up 4.7m with 4mm bottom and reverse chine the Ranger has the size and strength to get the job done. With the checkerplate floor and 5 seat positions the deck can be opened up to give you the freedom to move comfortably about your boat as you reel in the big one!



For the latest & additional information on this model please visit www.seajayboats.com.au/ranger or scan the QR Code with your Smart Phone



SEEKER RUNABOUT

For an entry level runabout with more than just basic features, you can't go passed our Seeker range of aluminium boats. A carpeted floor forward of the rear thwart seat allows for easy movement around the craft with a drop down floor in the cockpit area creating welcomed leg room. An opening windscreen allows for simple access to the anchorwell and bollard tie off point while a full tank rack effortlessly holds a fuel tank and battery if need be. Seating comes in the form of standard folding upholstered pedestals with a rear thwart seat for additional passengers. The Seeker comes well equipped to make your boating experience a pleasant one.



For the latest & additional information on this model please visit www.seajayboats.com.au/models/runabout/seeker or scan the QR Code with your Smart Phone



SPECIFICATIONS

	4.2	4.4
bottoms (mm)	2.0	2.0
sides (mm)	1.6	1.6
beam (m)	1.95	1.97
depth (m)	0.99	0.99
depth – incl. w/screen rail(m)	1.49	1.49
floor ribs	9	10
no. of persons	4	4
weight approx (kg)	193	222
rec hp	30	30
max hp	40	40
max motor weight (kg)	98	110

FEATURES

anchorwell	•	•
bungs – 38mm x 2	•	•
dash & control panel	•	•
flotation – under floor	•	•
gunwhale rubber inserts	•	•
handles – front & rear	•	•
rear corner gussets	•	•
rope cleat	•	•
rope shelf	•	•
spray chines	•	•
step down front floor	•	•
steering - hydraulic	opt	opt
steering – push pull	•	•
tank rack	•	•
towing eye – double	•	•
transducer bracket	•	•
windscreen – opening	•	•

TRANSOM

standard (l/s)	•	•
----------------	---	---

RAILS

windscreen	•	•
bow – short	•	•
rear	•	•

SEATS

rear thwart – welded	•	•
standard folding	•	•
seat sockets	3	3

SPECIFICATIONS

	4.2	4.4	4.55
bottoms (mm)	2.0	2.0	3.0
sides (mm)	1.6	1.6	3.0
beam (m)	1.95	1.97	2.10
depth (m)	0.99	0.99	1.10
depth – incl. w/screen rail (m)	1.53	1.53	1.52
floor ribs	9	10	12
no. of persons	4	4	5
weight approx (kg)	254	312	355
rec hp	40	40	50
max hp	40	50	60
max motor weight (kg)	110	120	120
overall length (m)	4.2	4.55	4.7

FEATURES

	opt	opt	opt
accessory pre rig	opt	opt	opt
anchorwell	•	•	•
battery & oil rack – in stern	•	•	•
bollards x 1	•	•	•
bollards x 3	•	•	•
bow sprit & roller	•	•	•
bungs – 38mm x 2	•	•	•
cut away dash	•	•	•
dashboard glovebox	•	•	•
floor – carpeted plywood	•	•	•
floatation – under floor	•	•	•
gunwhale rubber inserts	•	•	•
handles – rear	•	•	•
paint – chine up & inside (coloured sides opt)	•	•	•
pinstriping	•	•	•
rod holders x 2	•	•	•
rope shelf	•	•	•
side pockets	•	•	•
spray chines	•	•	•
steering – hydraulic	opt	opt	opt
steering – push pull	•	•	•
step down front floor	•	•	•
sure trac hull – reverse chine	•	•	•
towing eye – double	•	•	•
transducer bracket	•	•	•
wide side decks	•	•	•
windscreen – opening	•	•	•

TRANSOM

Motorwell (l/s)	•	•	•
ultimate edge (l/s)	•	•	•

FUEL TANK

under floor – deck fill	•	65	65
-------------------------	---	----	----

RAILS

bow – low profile / nav light plates	•	•	•
rear	•	•	•
transom	•	•	•
windscreen	•	•	•

SEATS

folding rear lounge	opt	opt	opt
full upholstered seats & pedestals	opt	2	2
full upholstered folding seats & pedestals	2	opt	opt
seat sockets	5	3	3

RUNABOUT CLASSIC

For those of you that expect something more than a basic runabout, our Classic models have so much to offer. At first glance you will notice the ever glossy 2pac paint with our modern pinstripe design for style and flair. Low bow rails have been fitted to an alloy bow sprit which assists in easier anchor retrieval. Fully upholstered seats are standard issue and for extra passengers, a rear folding lounge and backrest make for a welcome option. A filled in transom comes in the form of a motorwell with the exception of the 4.55m model which has an ultimate edge transom. The Classic is an ideal runabout that delivers comfortable boating for the family day out.



For the latest & additional information on this model please visit www.seajayboats.com.au/models/runabout/classic or scan the QR Code with your Smart Phone



CAPRI RUNABOUT

If you are interested in a boat that the whole family can enjoy, then our Capri range of runabouts might just be the answer. Several key features separate the Capri from other typical runabout models with the first being a walkthrough dash and screen that allows reaching your anchor a breeze. Modern designed fibreglass (not cheap plastic) dashes have been fashioned into the console area that oozes style with a fully lockable Glovebox to keep valuables safe. From fishing to skiing, every member of the family can enjoy themselves in our elite runabout range, the Capri.



For the latest & additional information on this model please visit www.seajayboats.com.au/models/runabout/capri or scan the QR Code with your Smart Phone



SPECIFICATIONS

	4.55	4.85	5.0	5.4	5.8	6.1
bottoms (mm)	3.0	3.0	3.0	4.0	4.0	4.0
sides (mm)	3.0	3.0	3.0	3.0	3.0	3.0
beam (m)	2.10	2.15	2.24	2.44	2.44	2.49
depth (m)	1.10	1.15	1.21	1.30	1.35	1.40
depth – incl. w/screen rail (m)	1.47	1.52	1.62	1.70	1.80	1.85
floor ribs	12	13	13	15	16	17
no. of persons	5	5	5	6	6	7
weight approx (kg)	348	401	440	563	570	688
rec hp	50	60	75	100	130	150
max hp	60	80	100	135	150	175
max motor weight (kg)	120	180	195	230	230	272
overall length (m)	4.7	4.95	5.2	5.67	5.92	6.22

FEATURES

accessory pre rig	opt	opt	opt	opt	opt	opt
anchorwell
battery & oil rack – in stern
bollards x 3
bow sprit & roller
bungs – 38mm x 2
dive door	-	-	-	.	.	.
drink holders x 2
fibreglass dash – glovebox
floor – carpeted plywood
flotation – under floor
gunwhale rubber inserts
ladder	opt	opt	opt	opt	opt	opt
paint – chine up & inside (coloured sides opt)
pinstripping
pocket nets
rod holders x 2
side pockets
ski hooks x 2	-	-	-	.	.	.
spray chines
steering – hydraulic	opt	opt	opt	.	.	.
steering – push pull
step down front floor
storage hatch – in floor between seats	-	-	-	.	.	.
sure trac hull – reverse chine
towing eye – double
transducer bracket
wide side decks
windscreen- walkthrough

TRANSOM

ultimate edge (l/s)	.	.	.	-	-	-
ultimate edge (ul/s)	-	-	opt	.	.	.

FUEL TANK

under floor / deck fill/gauge	65	80	100	140	160	220
-------------------------------	----	----	-----	-----	-----	-----

RAILS

bow – low profile / nav light plates
rear & transom
windscreen

SEATS

driver slide pedestal	-
folding rear lounge	opt	opt	opt	-	-	-
folding rear lounge (¾)	-	-	-	opt	opt	opt
full upholstered pedestal	2	2	2	2	2	2
seat sockets	3	-	-	-	-	-

SPECIFICATIONS

	4.8	5.0	5.4	5.8	6.1
bottoms (mm)	3.0	3.0	4.0	4.0	4.0
sides (mm)	3.0	3.0	3.0	3.0	3.0
beam (m)	2.15	2.24	2.44	2.44	2.49
depth (m)	1.15	1.21	1.30	1.35	1.40
depth – incl. w/screen rail (m)	1.54	1.58	1.69	1.75	1.80
floor ribs	13	13	15	16	17
no. of persons	5	5	6	6	7
weight approx (kg)	430	471	614	625	770
rec hp	60	75	110	130	150
max hp	80	100	135	150	175
max motor weight (kg)	180	195	230	230	272
overall length (m)	4.95	5.2	5.67	5.92	6.22

FEATURES

accessory pre rig	opt	opt	opt	opt	opt
anchorwell
battery & oil rack – in stern
bollards x 3
bow sprit & roller
bungs – 38mm x 2
consoles (side) x 2 – fibreglass dash/glovebox
dive door
drink holders x 2
drop in dash between consoles
floor – carpeted plywood
floatation – under floor
front cast platform – storage underneath
gunwhale rubber inserts
ladder	opt	opt	opt	opt	opt
paint – chine up & inside (coloured sides opt)
pinstripping
pocket nets
rod holders x 2
rounded foredeck
side pockets
ski hooks x 2
spray chines
steering – hydraulic	opt	opt	.	.	.
steering – push pull
step down front floor
storage hatch – in floor between seats
sure trac hull – reverse chine
towing eye – double
transducer bracket
wide side decks
windscreen- walk thru

TRANSOM

ultimate edge (l/s)
ultimate edge (ul/s)	.	opt	.	.	.

FUEL TANK

under floor / deck fill/gauge	80	100	140	160	220
-------------------------------	----	-----	-----	-----	-----

RAILS

bow – low profile / nav light plates
rear
transom
windscreen

SEATS

bow cushions with back rest	opt	opt	opt	opt	opt
driver slide pedestal
folding rear lounge	opt	opt	.	.	.
folding rear lounge (¾)	.	.	opt	opt	opt
full upholstered pedestal	2	2	2	2	2

BOWRIDER **WANDERER**

Explore new horizons in our bowrider style of boat, the Wanderer. The Wanderer comes standard with a carpeted front cockpit including a mid-section that can be installed and used as a full cast platform or if boating in comfort is more your style, you have the option of bunk cushions for comfortable seating. An optional folding rear lounge may also be fitted for additional seating. Stylish fibreglass (not plastic) dashes are included that one could be forgiven in thinking that they sitting behind the wheel of a car. Whether it be touring the waterways at your leisure or casually wetting a line, the Wanderer will always be ready to entertain.



For the latest & additional information on this model please visit www.seajayboats.com.au/models/bowrider/wanderer or scan the QR Code with your Smart Phone



VENTURE CAB CABIN

Looking for a cabin style boat that feels right at home in offshore conditions with true long range capabilities? Then look no further than our VENTURE CAB range of aluminium boats. Each model has been designed with a spacious cabin that can accommodate fishing and safety gear aplenty while effectively harboring you from the elements should the weather turn nasty. Looking inside the hood lined cabin you will discover a V berth bunk arrangement that's just perfect for an overnight stay. Our Ultimate Edge Transom and Sure Trac Hull configuration enhances performance, reliability and fuel economy to give you a ride that's second to none as you head towards your favorite patch of reef.



For the latest & additional information on this model please visit www.seajayboats.com.au/models/cabin/venture-cab or scan the QR Code with your Smart Phone



SPECIFICATIONS

	5.0	5.4	5.8	6.1
bottoms (mm)	3.0	4.0	4.0	4.0
sides (mm)	3.0	3.0	3.0	3.0
beam (m)	2.24	2.44	2.44	2.49
depth (m)	1.21	1.30	1.35	1.40
depth – incl. w/screen rail (m)	1.96	2.04	2.15	2.20
floor ribs	13	15	16	17
no. of persons	5	6	6	7
weight approx (kg)	505	679	690	805
rec hp	75	100	130	150
max hp	100	135	150	175
max motor weight (kg)	195	230	230	272
overall length (m)	5.2	5.67	5.92	6.22

FEATURES

accessory pre rig	opt	opt	opt	opt
anchorwell
bait board	opt	opt	opt	opt
bait tank	opt	opt	opt	opt
battery & oil rack – in stern
bollards x 3
bow sprit & roller
bungs – 38mm x 2
dive door	-	.	.	.
drink holders x 4
floor – carpeted plywood
flotation – under floor
front opening hatch
gunwhale rubber inserts
ladder	opt	opt	opt	opt
nav lights
paint – chine up & inside (coloured sides opt)
pinstriping
rear instrument cover	-	.	.	.
rod holders x 2
side pockets
side pockets - cabin	opt	opt	opt	opt
ski hooks x 2	-	.	.	.
spray chines
steering – hydraulic	opt	.	.	.
steering – push pull	.	-	-	-
sure trac hull – reverse chine
towing eye – double
transducer bracket
wide side decks

TRANSOM

ultimate edge (l/s)	.	-	-	-
ultimate edge (ul/s)	opt	.	.	.

CABIN

bunks – carpeted / storage underneath
cabin lining
moulded instrument & steering panel
windscreen

FUEL TANK

under floor / deck fill / gauge	100	140	160	220
---------------------------------	-----	-----	-----	-----

RAILS

bow – split
cabin
transom
rear
windscreen

SEATS

front bunk cushions	opt	opt	opt	opt
driver slide pedestal
folding rear lounge	opt	-	-	-
folding rear lounge (¾)	-	opt	opt	opt
full upholstered pedestal	2	2	2	2
full upholstered seats on storage & seat box	opt	opt	opt	opt

Pinstripe

Standard Pinstripe
Choice of two colours



Deluxe Pinstripe
Choice of three colours



Go to our website to choose your own colour combinations.
Please note: Colours shown are approximate

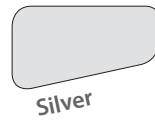
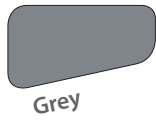
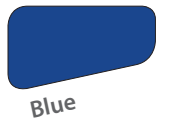
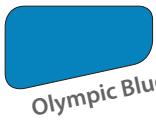
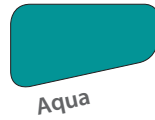
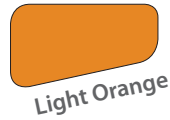
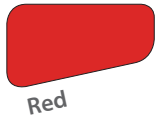
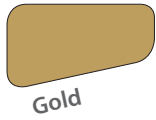
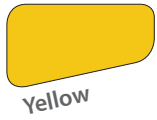

Dimension Terms

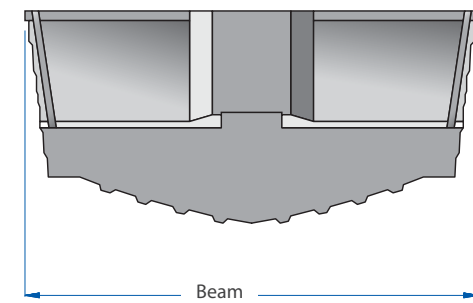
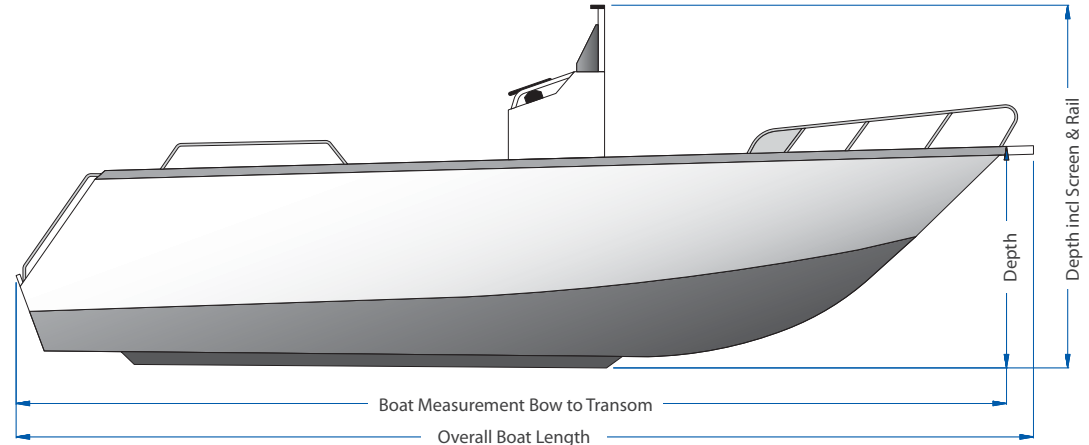

Upholstery Colours

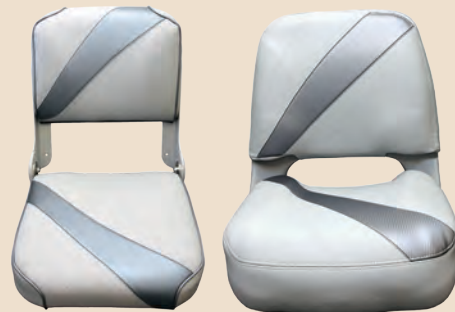
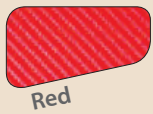
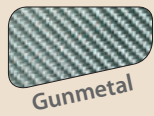

Grey plus one colour

Optional Painted Side Hull Colours

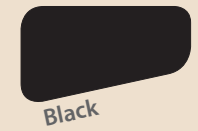

Accessories

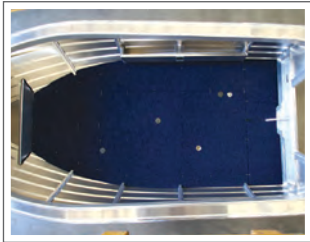

Floor - Full

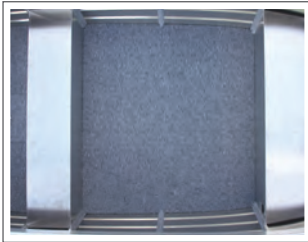

Floor - Part

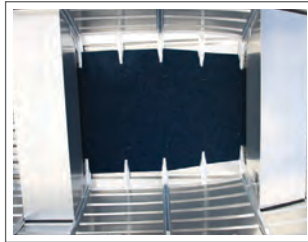

Floor - Three Quarter

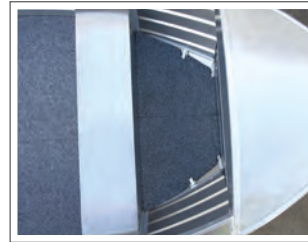

Floor - Front

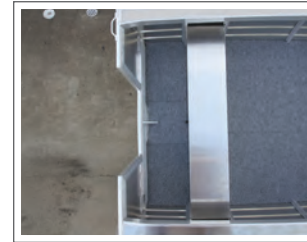

Floor - Rear



Part Casting Platform



Standard Plastic Seat



Full Upholstered Seat



Full Upholstered Folding Seat



Seat Socket



Rear Lounge - Ultimate Edge



Rear Lounge - Three Quarter



Rear Lounge Moterwell Models

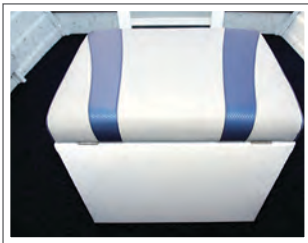

Storage Box with Upholstered Lid



Anchor Well Suits Standard Decks



Drink Holder - Standard



Deck Filler



Accessory Pre Rig Kit

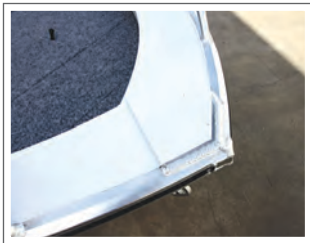

Electric Motor Plate



Electric Motor Plate - extended off Gunwhale

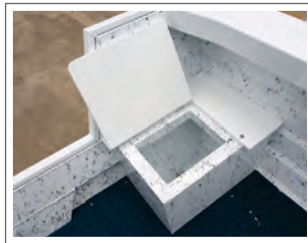

Live Bait Tank - In Floor



Live Bait Tank - Plastic

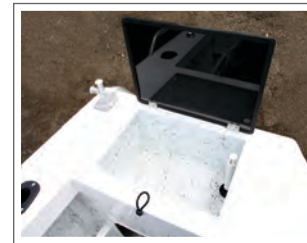

Live Bait Tank - Alloy

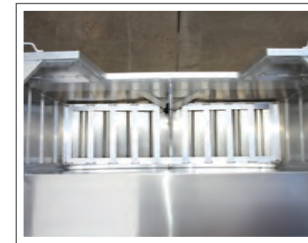

Full Tank Rack

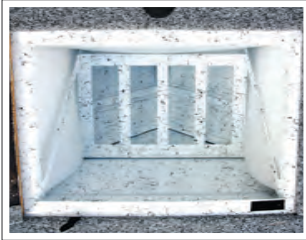

Half Tank Rack Suits 45ltr Tank



Deck Wash - Salt Water



Handles & Rope Cleat



Rear Step & Rail



Ski Tow Eye

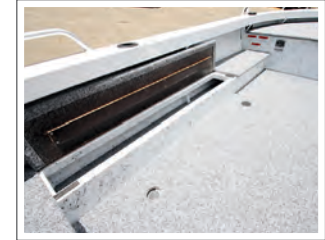

Rod Locker Above Floor



Side Pocket



Set Down Foredeck



Low Bow Rail



Short Front Rails



Short Rear Rail



Side Console



4.85 - 5.0m Folding Console

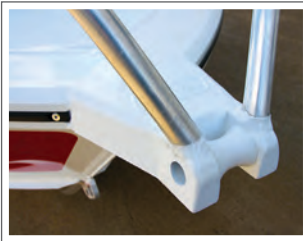

Bow Spit & Roller



Small Bollard



Removeable Bait Board



Navigation Light Plates



Shoulder Mount Plate

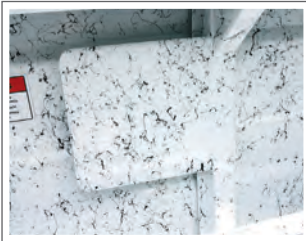

Switch Mount Plate



Transducer Bracket



Folding Alloy Targa



Plastic Rod Holder

Not all accessories and options available are shown, please refer to your dealer for the full extensive range or visit www.seajayboats.com.au/options/accessories online or by scanning the QR code.



Warranty

SEAJAY GROUP PTY LTD ACN 141 380 298

This document states terms of the Warranty given by the Company in respect of products manufactured by it.

1. INTERPRETATION

“The Company” means SEAJAY GROUP PTY LTD ACN 141 380 29

“The Purchaser” means the original person or entity of any boat sold through an authorised SeaJay Boats Dealership.

“Boat” means any aluminium boat or accessory which is manufactured by the Company.

“Warranty Period” means the period of two years (24 months) from the date of delivery to the ORIGINAL purchaser.

In this document:-

2. WARRANTY

The Company warrants to the Purchaser that:-

The quality of the materials used in the construction of the boat are in accordance with, or above, the standard usual in the aluminium boat building industry; and

The boat will remain free of defects during the warranty period.

3. WORKS UNDER WARRANTY

To obtain the benefit of the warranty the Purchaser must return the boat to the place of purchase.

Warranty does not cover any consequential expenses beyond the warranty repair itself. Eg. Freight

SeaJay Boats shall not be liable for consequential loss of any kind arising out of the supply or operation of the Boat.

4. EXCLUSIONS

The warranty will not cover any defect or damage caused by:-

Operating outside design limitations:

Misuse, abuse or negligence

Normal Wear and Tear.

Use of a motor which has more power or weight than is recommended on the compliance plate attached to the Boat.

Improper Trailer fitup. Eg. Incorrect tie down of Boat to Trailer, the use of multi roller Trailers, no Engine support bracket and off road use.

Paint is not warranted against the effects of oxidization, wear and tear, electrolysis or damage caused by fuel and dissimilar metals.

This also includes normal oxidization around unsealed edges and fittings.

Carpet, Timber Floors , Upholstery and Windscreens (including console screens) are limited to a 12 month warranty only.

Any alterations / modifications to the Boat once it has left the factory will void any/all remaining warranty.

5. COMMERCIAL USE

Due to the variance in usage and conditions which may be experienced, the Purchaser must be satisfied the intended Boat is suited for commercial applications.

This Warranty does not cover any boat which has been used for a commercial purpose.

6. EXCLUSION OF FURTHER WARRANTIES

Except as stated in this document, no warranty express or implied is given by the Company except any warranty which is implied by law.



Disclaimer

As Sea Jay continues to make improvements to our product, we do reserve the right to change any details that are contained herein.

All specifications quoted are approximate and subject to change.

Please note that photos may show accessories or options that are not standard, please check the features for the standard options applicable.

For further information on the Sea Jay Model range please contact your authorised Dealer as Sea Jay Aluminium Boats do not sell our Pressed Range direct from the factory.

Dealer Network

Our National Dealer Network will provide you with updated information and marketing of our product. As fishing and boating needs differs in various parts of our nation, our Dealer Network will provide the right product for their area. However if your needs call for a variation. Sea Jay have a range of optional accessories and fittings to meet your needs.



General Maintenance

It is important to follow a few basic rules in providing regular maintenance to your new vessel.

- Always thoroughly wash your entire vessel with fresh water and mild detergent after use.
- A spray of a protective lanolin based product should be re-applied after washing, to all areas where dissimilar metals are fitted. eg. Any Stainless Steel fittings (Windscreen Bolts, Rod Holders, Baitboard etc.)
- If an accessory is fitted after market (not factory fitted) it is important to spray a protective lanolin based product to these areas where salt or moisture can be attracted.
- Leave your vessel permanently tilted to drain after use.

More Detailed information is available within our Owners Manual.



For more information, contact your authorised Sea Jay Boats dealer

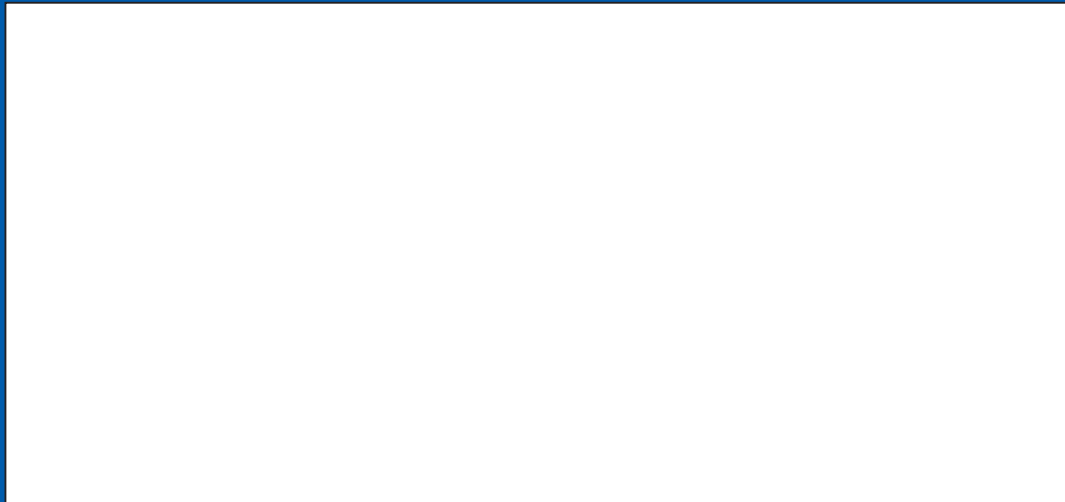

2 Maddison Court, Bundaberg Qld 4670
Ph: 07 4152 2111 Fax: 07 4153 5075
Web: www.seajayboats.com.au

DELUXE MODELS
Edition 12 - Dated August 2012